



Performance of low impact development on peak flow reduction in an urban system

M. Pampaloni¹ | A. Sordo-Ward²  | M. Lompi¹  | T. Pacetti¹  | S. Zubezu³  |
 L. Rodríguez-Sinobas³  | P. Bianucci²  | E. Caporali¹  | L. Garrote² 

¹Department of Civil and Environmental Engineering, University of Florence, Florence, Italy

²Departamento de Ingeniería Civil: Hidráulica, Energía y Medio Ambiente, Universidad Politécnica de Madrid, Madrid, Spain

³Departamento de Ingeniería Agroforestal, Universidad Politécnica de Madrid, Madrid, Spain

Correspondence

E. Caporali, Department of Civil and Environmental Engineering, University of Florence, Florence, Italy.
 Email: enrica.caporali@unifi.it

Abstract

This study proposes an approach to evaluate the efficiency of low impact development (LID) in reducing urban runoff using a rainfall generator to disaggregate daily rainfall into sub-hourly rainfall data, which are used as input of a hydrological model at the urban watershed scale. Twelve scenarios are analyzed combining four percentages of impervious area retrofitted with LIDs (25%, 50%, 75% and 100%), and three LID combinations of green roofs (GRs) and rain gardens (RGs). The rainfall generator Rainsim V.3 is used to generate 500 years of rainfall data with a 15-min time step to analyze the performance of LIDs in the long-term with the LID module of the Soil and Water Assessment Tool hydrological model. An urban watershed of 3 km² located in Florence (Italy) is selected as a case study. Results show the performances of GRs and RG on peak flow reduction, highlighting a maximum flow reduction of single facilities ranging between 15% and 60% that can improve in case of their combination. The hydrological performances of LID combinations are very sensitive to the intensity of rainfall events, as well as percentages of area treated underlining the importance of simulating multiple scenarios of intervention to determine the most efficient combination of LIDs for a given case study and support their proper design from a urban water hydrology perspective.

KEYWORDS

runoff, urbanization, watershed management, stochastic models

1 | INTRODUCTION

Low impact development (LID) practices (or Sustainable urban Drainage System—SuDS) are increasingly drawing attention as a solution for sustainable storm water management and runoff reduction in urban watersheds (Bai et al., 2019; Li et al., 2017). Indeed, LID retrofitting of impervious land use surfaces can mimic the pre-development hydrology of urban areas, and thus mitigate the impacts on water quality and

Paper No. JAWR-22-0051-P of the *Journal of the American Water Resources Association* (JAWR).

Discussions are open until six months from publication.

This is an open access article under the terms of the [Creative Commons Attribution-NonCommercial-NoDerivs](https://creativecommons.org/licenses/by-nc-nd/4.0/) License, which permits use and distribution in any medium, provided the original work is properly cited, the use is non-commercial and no modifications or adaptations are made.

© 2024 The Authors. *Journal of the American Water Resources Association* published by Wiley Periodicals LLC on behalf of American Water Resources Association.

Research Impact Statement

Integration of SWAT (Soil Water Assessment Tool) model with a stochastic rainfall generator to analyze runoff reduction of low impact development scenarios in an urban watershed in Florence (Italy).

quantity caused by intensive urbanization (Gong et al., 2021; Hoghooghi et al., 2018; Rezaei et al., 2019). LIDs can reduce peak flow rate and flow velocity as well as extend concentration time, restoring water balance, and improving water quality (Ahiablame et al., 2013; Roy-Poirier et al., 2010). Recent studies have reported key findings on the effectiveness of different LIDs on water quantity treatment (e.g., peak flow and runoff volume reduction) and quality at local scales (Ercolani et al., 2018; Zhang & Guo, 2013; Zubelzu et al., 2019). In addition, LID hydrological performances at different spatial scales have been assessed to support their adoption as a solution to control stormwater in urban watersheds (Yang et al., 2020). However, the evidence of LID effectiveness at the watershed scale is limited (Andrés-Doménech et al., 2018; Kim & Kim, 2021). Therefore, questions remain about how LID practices can individually or cumulatively affect urban watershed hydrology.

Another critical issue regards the analysis of LID performances on the long temporal scale. Indeed, most studies use hydrological modeling and single design rainstorms with short duration characterized by key features such as the mean/maximum intensity or the total rainfall volume. Some authors pointed out that LID practices need to be evaluated as a sustainable measure for long-term functioning (Stovin et al., 2013), thus analyzing hydrological responses under all rainstorm events that occur during multiple years possibly using data with sub-hourly temporal resolution. Indeed, the effectiveness of LIDs in treating water pollutants, reducing runoff, and managing urban stormwater can vary depending on seasons and on the alternance and timing of wet and dry periods (Caporali et al., 2021; Fatichi & Caporali, 2009) and potentially influencing their long term cost-effectiveness (Yang et al., 2020). However, there is a lack of literature regarding long-term LIDs performance analysis, since observed climatic data with sub-daily temporal aggregation are usually scarce (Morbidelli et al., 2020). In addition, the temporal aggregation of rainfall and other climatic data are usually daily, even if it is too coarse for LID modeling purposes. Rainfall disaggregation from stochastic rainfall generators may be an option to obtain fine-scale rainfall data to support long-term performance of LIDs (Andrés-Doménech et al., 2010; Pampaloni et al., 2021). Pampaloni et al. (2021) demonstrated the potential of a temporal disaggregation methodology, based on the stochastic rainfall generator RainSim V.3. (Burton et al., 2008, 2010), to reproduce key features of the rainfall pattern and volumetric percentiles commonly used in the design of LIDs (Sordo-Ward et al., 2019).

However, studies that couple stochastic climatic data and hydrological models to test the effectiveness of LID at the watershed scale are still lacking. A critical aspect is the selection of suitable tools to properly describe LID effects on watershed processes. Kaykhosravi et al. (2018), pointed out a list of properties that LID models should have at the watershed scale: (i) representation of all natural processes occurring in an LID; (ii) capability of simulating long-term continuous LID hydrology; (iii) representation of synergies between LIDs and urban watershed hydrology; (iv) simulation of LID connections with existing sewers. The use of climatic data with a fine temporal resolution should be preferred since LIDs are usually placed in urban watersheds with small size and short concentration time. Among others, Hydrus 1D/2D and GIF-MOD models have been widely used in previous studies that focused on exploring the synergies between LID properties and their performances (Li et al., 2018; Massoudieh et al., 2017; Turco et al., 2017). The performance of LID practices has also been evaluated under different urban land use scenarios using the Soil and Water Assessment Tool (SWAT) (Marhaento et al., 2019; Uniyal et al., 2020) demonstrating that the effectiveness of LID practices differs among urban land use densities (Seo et al., 2017). Likewise, Her et al. (2017) also proposed an innovative LID computational module integrated into the sub-hourly simulation of SWAT components. The module simulates the hydrological processes of predefined facilities, which include green roof (GR), rain garden (RG), cistern, and permeable pavements among the hydrological response unit (HRU) where LIDs are implemented. Furthermore, the SWAT-LID module together with the sub-hourly simulation capability, allows the SWAT model to be a viable tool for evaluating urban watershed processes in a distributed and process-based manner (Shannak, 2017).

Considering this background, this study aims at assessing how LID implementations affect watershed hydrologic responses in a highly urbanized area through a long-term stochastic modeling. The long-term modeling is done by coupling SWAT with a stochastic methodology to generate sub-hourly rainfall series to assess the LIDs performance for extreme events (de Sousa et al., 2020; Huang et al., 2020; Wadzuk et al., 2017) particularly focusing on Peak Flow Reduction (PFR). Indeed, the highest return period of short-duration events can be properly assessed only if long time series with a fine temporal resolution are considered. Nevertheless, time series with sub-hourly resolution are usually short, as they are provided by more recent rain gauges (Morbidelli et al., 2020). The continuous modeling can describe the interaction between single storms, as each event is influenced by the distance (inter-event time) with the previous event. This methodology allow the evaluation of the performances of different LIDs (GRs, RGs and their combination) in reducing the peak flow for different rainfall intensities also assessing the potential of every LID scenario in reducing the maximum peak flow (i.e., analyzing PFR for events with different return periods). The study is divided in the following sections: the methodology and the data that have been used are shown in Section 2; Section 3 contains the results that are described and interpreted for the different LID scenarios analyzed, while their discussion can be found in Section 4; the conclusions are in the Section 5.

2 | MATERIALS AND METHODS

This section provides the general methodology used in the study and shows the data that are used in each step to obtain the final results. The flow chart of the methodology is shown in Figure 1.

First, a temporal disaggregation of rainfall series was achieved based on the Neyman-Scott rectangular pulse method by the stochastic rainfall generator RainSim V.3 (Pampaloni et al., 2021). An urban watershed located in Florence (Italy) was selected as a case study and a 20-year series of observed precipitations, recorded by the Florence University rain gauge (Florence, Italy), was used to calibrate the stochastic rainfall generator. A 500-year rainfall series with a 15 min time step was generated using the stochastic rainfall generator RainSim V.3 to evaluate the long-term performance of the LID scenarios. The LID scenarios are compared with a baseline scenario, that is, the watershed configuration without LIDs, which has been described in SWAT with the HRU, areas of the watershed with similar land use, soil, and topographic data. LID scenarios are implemented by the SWAT-LID module (Her et al., 2017) within a sub-hourly SWAT model routine.

Two LID types are joined to generate different LID combinations and, for each of them, growing retrofitting areas among the watershed are considered. A total of 12 LID scenarios are composed by mixing three LID combinations (GR, RG, GR + RG) and four percentages of impervious areas where LIDs, are installed (25%, 50%, 75% and 100%), i.e. LIDs occupy different percentages of the impervious area within a given HRU.

Flow series are extracted by the reach scale output of the LID module for the baseline and LID scenarios to evaluate the PFR between a LID and the baseline scenarios for every flow event extracted from the 500years long-term output of the model. Second, the PFRs corresponding to the annual maximum peak flows of every LID scenario are analyzed with the empirical return period associated with each event. Moreover, the percentages of PFR are evaluated also considering each single storm in the generated timeseries, which are extracted considering different values of Minimum Inter-event Time (MIT). The PFRs are then analyzed with respect to the corresponding rainstorm event intensities (Section 2.4). Moreover, a sensitivity analysis of the results based on MITs has been conducted. This section is further divided into four parts to better describe the case study (Section 2.1), the SWAT model setup (Section 2.2), the identification of independent flow events (Section 2.3), the evaluation of the PFR of the LID configurations is done by considering single storms with different rainfall intensities and annual maximum rainfall (Section 2.4).

2.1 | Case study

The case study area is within the city of Florence, in Tuscany (central Italy). It covers about 3 km² inside a highly urbanized area (Figure 2). The topography is flat, on average 50 m.a.s.l. Topographic information was obtained from the 1 m LIDAR DEM distributed by the Tuscany Regional Administration, which was used to delineate the boundaries of the watershed and to identify the drainage network. According to the LIDAR DEM, the average slope of the study watershed is 2.1% and the length of the longest flow path is 4.3 km (blue line in Figure 2). The concentration time of the urban watershed is 19 min.

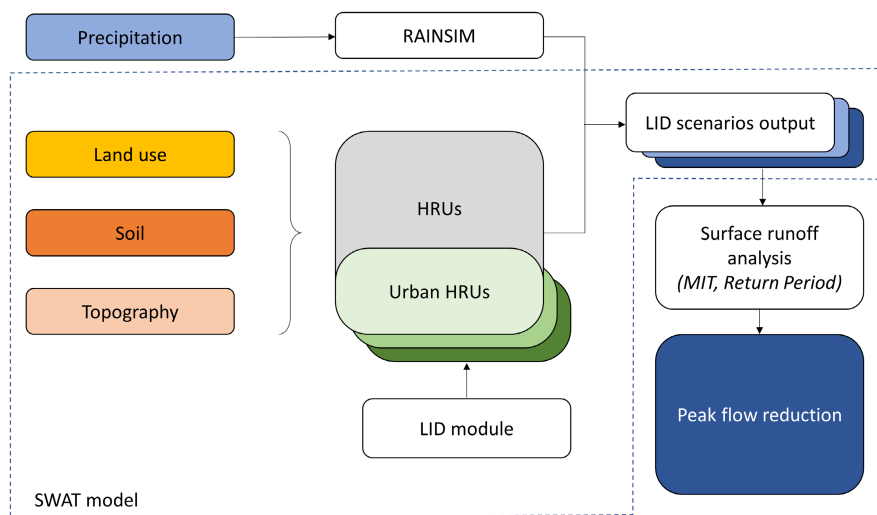

FIGURE 1 Flowchart of the methodology to assess the performance of the low impact development (LID) scenarios in reducing the peak flow in the urban watershed. HRU, hydrological response unit; MIT, Minimum Inter-event Time; SWAT, Soil and Water Assessment Tool.

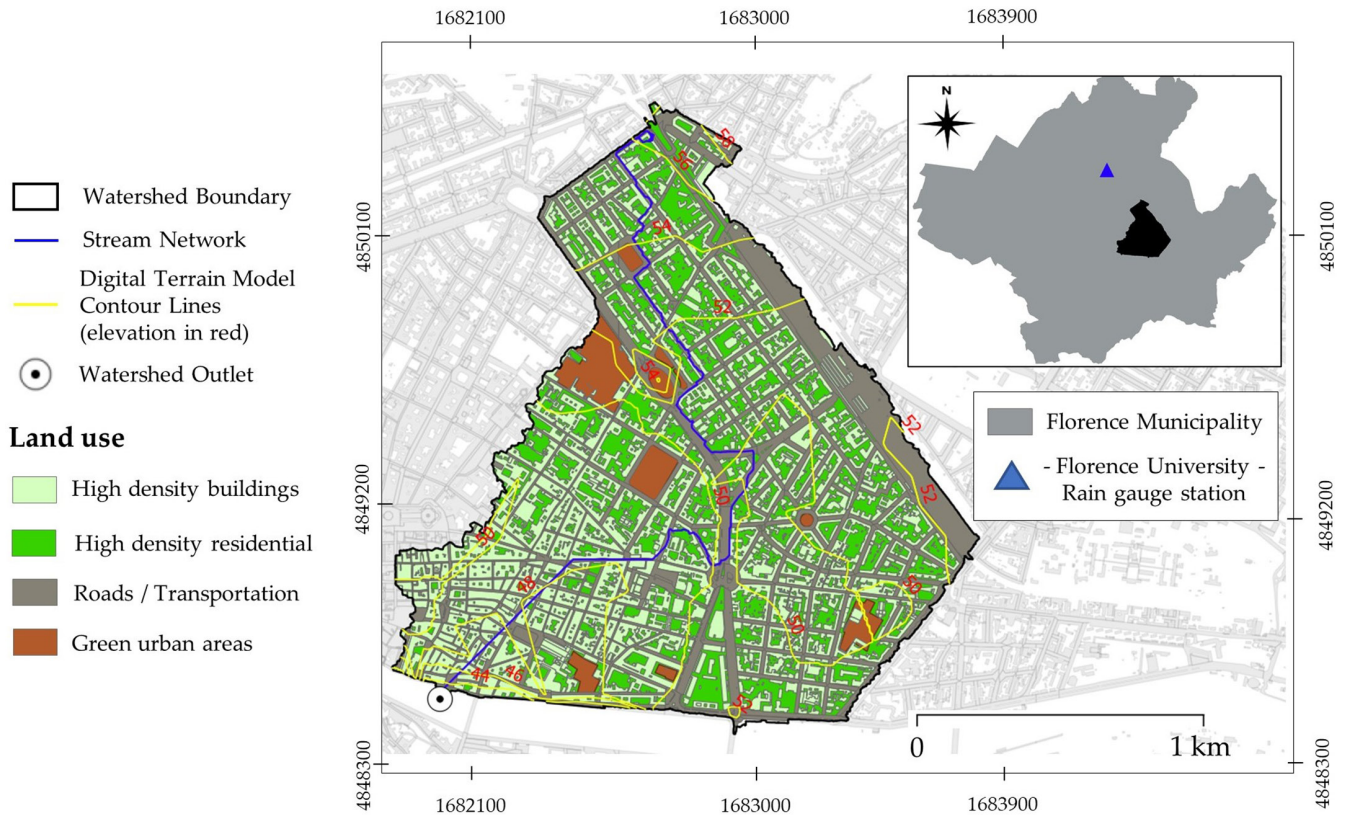

FIGURE 2 Location and land use of the study urban watershed. The blue triangle indicates the rainfall gauge location within the municipality area of Florence.

2.2 | SWAT model set-up

SWAT model was implemented in the urban watershed using a sub hourly time interval. As reported in Brighenti et al., 2019, the sub hourly SWAT simulation is based on the Green-Ampt Mein- Larson infiltration routine (Mein & Larson, 1973). Baseflow and evapotranspiration are calculated on a daily basis and then equally distributed for the selected time step (Jeong et al., 2010). The routing phase is typically divided into two main components: the Surface Flow Routing and the Channel Routing. The first one uses a modified version of the kinematic wave method to simulate the movement of surface runoff within each sub-basin, considering factors like flow velocity and slope to estimate how runoff travels over the land surface. The second one uses the Muskingum-Cunge method (or other suitable routing methods) to simulate the routing of runoff through streams and rivers.

The model is chosen for LID analysis, as it is capable to: (i) represent hydrological processes from small HRU scale to large-scale watersheds; (ii) simulate continuous long-term watershed hydrology considering the soil moisture between storm events assessing infiltration, evapotranspiration and percolation (Her et al., 2017), use sub-daily and sub-hourly time-step climate input to provide sub-hourly outputs (Jeong et al., 2010; Maharjan et al., 2013); (iii) model the LID wet and dry continuous cycles over long-term modeling. In SWAT, a river basin or an urban watershed can be divided into subbasins based on the stream network, and each of them is divided based on HRUs. An HRU, as shown in Figure 1, is a unique combination of slope, land use, and soil type that has the same hydrological behavior regarding water runoff.

2.2.1 | SWAT-LID module

The SWAT-LID module offers four types of pre-set LIDs: GRs, RGs, cisterns, and permeable pavements. Each of them can be assigned with a different percentage of impervious treated area in the HRU where the LIDs are installed (Figure 3). This percentage of impervious HRU area is then treated according to the LID characteristics and contributes proportionally to the total HRU output. The runoff is generated in a separated way in the impervious and in the pervious area, and once both runoff depths are calculated, the overall runoff depth of the HRU is calculated proportionately to the areas of each part (more details can be found in Her et al., 2017). In this study, only GRs and RGs were selected as design facilities. These two LIDs types can be conceptualized as a temporary surface or subsurface water storage connected to other elements of the urban system and subjected to evaporation and percolation (Figure 4).

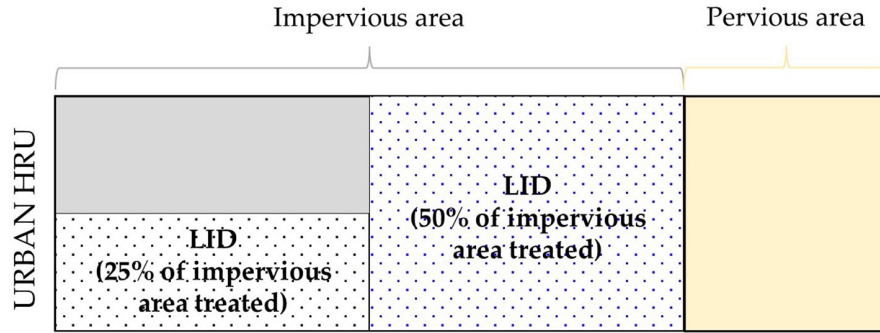

FIGURE 3 Example of LID implementation in an urban HRU. Impervious areas of the urban HRU can be retrofitted with LID depending on various percentages of area treated by the infrastructure.

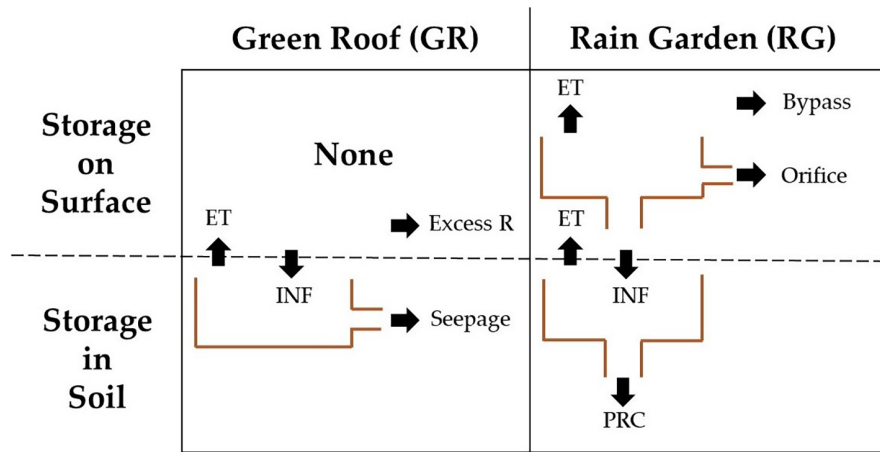

FIGURE 4 Storage of the three LIDs analyzed in SWAT simulation. Bypass, bypass of stormwater; ET, evapotranspiration; Excess R, excess rainfall; INF, infiltration; IRR, irrigation; Orifice, discharge of stormwater through an orifice; PRC, percolation of soil water; Seepage, seepage of soil water (adapted from Her et al., 2017).

A GR is a designated area in the HRU with a soil layer and vegetation. The soil layer retains rainwater and releases it through seepage. Soil properties such as depth, field capacity, wilting point, saturated hydraulic conductivity, and porosity can be modified in the LID module (Table 3). After soil saturation, the rainfall moves toward bypass seepage and runoff generation begins. Evapotranspiration and seepage rates are functions of soil moisture content and vary from field capacity to wilting point of the soil.

RGs are artificial depressions in which stormwater can be retained and infiltrated. In the LID Module, a RG is set to receive surface flow from the HRU impervious area, as well as raindrops that fall directly above it. A typical RG consists of two storage components (tanks): storage on the surface of the garden (upper tank) and an amended soil layer (lower tank). The water stored in the surface storage infiltrates the soil layer and then percolates into the native soil. The water pond in the upper tank can be discharged through an orifice pipe. Water stored in the upper and lower tanks can evaporate to the air and can also percolate to the native soil in the last. The depth, field capacity, wilting point, saturated hydraulic conductivity, and porosity of the amended soil chosen in GRs and RGs can be set in the LID Module (Table 3).

2.2.2 | Soil and land use data

Soil properties were obtained from the FAO/Unesco world soil digital map. The soil of the study area is composed of two layers of loam and sandy loam texture, respectively. The maximum rooting depth is 1 m. According to the Corine Land Cover 2018 database, land uses are composed of 29% roads/transport, 41% high-density buildings, 27% high density residential areas, and 3% green urban areas.

The percentage of impervious area associated with a land use type represents one of the most important characteristics of an HRU. In this environment, the default Total Impervious Amount of every urban land use inside the SWAT database was updated by the 2018 Copernicus imperviousness high resolution raster file (Lefebvre et al., 2016). After this data processing, about 94% of the study area is made up of impervious surfaces (Table 1). Since the scope of the study is to evaluate the performance of LIDs at the watershed scale, the urban basin is not further

TABLE 1 Urban land use features of the study watershed. Effective impervious amount—EIA—of every urban land use is presented.

SWAT code	Land use	Area (ha)	Watershed area (%)	EIA (%)
URHD_roofs	Residential high density (roofs)	123	41	95
URHD	Residential high density	81	27	89
UTRN	Transportation/roads	87	29	98

TABLE 2 LID scenarios implemented in the study watershed combining different LID types (green roof, GR and rain garden, RG) and percentage of treated area (25%, 50%, 75%, and 100%).

Land use SWAT code	LID type			Watershed area percentage
	GR	Cistern	RG	
LID scenario	UHD_roofs	UHD_roofs	URHD—URTN	
	Fraction of impervious area treated			
Baseline	0%	0%	0%	0%
GR—25	25%	0%	0%	9.7%
GR—50	50%	0%	0%	19.4%
GR—75	75%	0%	0%	25.9%
GR—100	100%	0%	0%	38%
RG—25	25%	0%	0%	13.1%
RG—50	50%	0%	0%	26.2%
RG—75	75%	0%	0%	34.8%
RG—100	100%	0%	0%	52.4%
GR + RG—25	25%	0%	25%	22.8%
GR + RG—50	50%	0%	50%	45.7%
GR + RG—75	75%	0%	75%	60.9%
GR + RG—100	100%	0%	100%	91.4%

divided into subbasins. In SWAT, there are various criteria to select or restrict the number of HRUs considered in every sub-basin. Here, the amount of HRUs in the watershed corresponds to the number of land use types in the basin.

2.2.3 | Climate data

Rainfall series with at least sub-hourly temporal aggregation are needed to run the sub-hourly SWAT-LID module routine. The temporal disaggregation of daily rainfall series and the generation of the long term time series is done in a previous study (Pampaloni et al., 2021), where all the information can be found. The stochastic rainfall generator RainSim V.3 was calibrated with the 20-year observed rainfall series which were aggregated at 24 h time step. The generator has been used in single-site versions, as just a rain gauge is involved. First, the analysis of the daily observed rainfall series is used to derive some statistics that are used in the calibration of RainSim.

The rainfall statistics for each month are the mean, variance, lag-autocorrelation, dry period probability and skewness. Five parameters were calibrated in each month: λ (1/mean waiting time between adjacent storm origins [1/h]); β (1/mean waiting time for rain cell origins after storm origin [1/h]); η (1/mean duration of rain cell [1/h]); ν (mean number of rain cells per storm [-]); ξ (1/mean intensity of a rain cell [h/mm]). After the calibration, RainSim has been used to generate a simulated rainfall series of 500 years with a 15 min time-step, which has been analyzed to see whether it is consistent with the observed one. The simulated time series is the input of the SWAT sub-hourly routine. The other four climatic variables (air temperature, solar radiation, wind speed, and relative humidity) were simulated with daily time step using WGEN, the internal SWAT stochastic Weather GENERator (Neitsch et al., 2005). WGEN can be used to fill in missing weather data and simulate weather parameters for which observed data are not available. The monthly parameters of rainfall (average, standard deviation, skewness, sequences of wet or dry days), temperature (maximum, minimum, dew point), wind speed and solar radiation required by WGEN (Neitsch et al., 2005) have been estimated using local available data. The climatic data (observed rainfall, air temperature, solar radiation, and relative humidity) from a series of 20 years (1998–2018) were recorded by the automatic gauge-station “Florence University” (id. TOS01001096). The

TABLE 3 Hydrological parameters of amended soil layers of GRs and RGs used in all the LID scenarios implemented.

Hydrological parameter	LID type		Parameter range
	GRs	RGs	
Depth (m)	0.8	0.5	0–1
Field capacity (mm/mm)	0.4	0.4	0–1
Wilting point (mm/mm)	0.15	0.15	0–1
Saturated hydraulic conductivity (mm/h)	350	350	0–500
Porosity (mm/mm)	0.5	0.5	0–1

gauge station is located at the School of Engineering—University of Florence (Figure 2), at an altitude of 84 m above sea level and its coordinates are E 1681124, N 4852004 (EPSG 3003 Monte Mario/Italy zone 1). Observed wind speed series, from 2004 to 2018, were obtained from the anemometric gauge ‘Amerigo Vespucci airport’, located 7 km from the studied urban watershed. All climatic data are recorded by the regional monitoring network and stored at a 15 min-temporal resolution by the Hydrological Service—SIR. The rain gauge measurements have a minimum resolution of 0.2 mm.

2.2.4 | LID scenarios

The combination of the two LID types resulted in three LID combinations: GR, RG, and GR + RG. For each of them, four fractions of impervious areas where LID are installed are analyzed: 25%, 50%, 75% and 100%. Finally, 12 LID scenarios are modeled (Table 2) to assess the effectiveness of stormwater management on a watershed scale using the LID scenarios. The scenarios corresponded to the mixing of LID combinations and the retrofit percentages. The corresponding percentages of the watershed retrofitted area for each LID scenario are also shown in Table 2. Each GR-XX scenario has the XX% of all the roofs converted into GRs, while RG-YY is another scenario in which the YY% of the impervious areas that are not roofs are converted into RGs. Therefore, the GR + RG-ZZ scenario implies ZZ% of the total area becomes permeable, being $ZZ = XX + YY$ the percentages of roofs and other (not roofs) impervious areas converted into GRs and RGs, respectively. For instance, as can be seen in Table 2, the 25% of all the roofs changed into GRs (GR-25) represent the 9.7% of the watershed area, while the 25% of impervious areas suitable for RGs (RG-25) is the 13.1% of the watershed area. The changes in the scenario GR + RG-25 affect 22.8% of the area, which is the summation in terms of area percentage of GR-25 and RG-25 (9.7% + 13.1%). Each type of LID was designed in the whole urban HRU of the study watershed, except for green urban areas.

Table 3 shows the hydrological parameters of amended soil layers of GR and RG. The values of the design parameters are calculated as in the SuDS manual (Woods Ballard & Construction Industry Research and Information Association, 2015). For RGs, the orifice configuration is set as in Her et al. (2017). The height of the orifice from the bottom of the RGs is set to 0.05 m.

2.3 | Identification of independent rainstorm and flow events

Rainstorm events are extracted from the long-term generated precipitation series following an approach based on MIT and a threshold value to define not-zero rainfall (Pampaloni et al., 2021). The value of 0.2 mm is chosen as a threshold because it is the minimum resolution of the Florence University gauge station. Two nonzero rainfall records can be considered as part of the same rainstorm event only if the time between them is less than or equal to the MIT. Indeed, MIT can be defined as the no-rainfall time between two consecutive not-zero rainfall records among the analyzed series (Behera et al., 2010).

The selection of accurate MIT values is crucial to define an independent rainstorm event in urban watershed analysis. First, if MIT is too short, some consecutive rainfall pulses can be erroneously considered as independent events. If it is too long, a single independent event can be erroneously composed by too many rainfall pulses that need to be separated into multiple independent events. Second, since it is designed to identify runoff events, MIT should be longer than the response time of the urban watershed. The response time is defined as the sum of the concentration time of the catchment and the detention time that urban runoff receives from stormwater management sewers. The response time of the study watershed at a rainfall impulse is equal to 30 min. Finally, the alternation of wet and dry periods needs to be considered. The goal of this study is to test the capacity of the LID combinations to reduce runoff when every facility is fully recovered; therefore, MIT must also consider the time that every LID process (infiltration, ponding, evapotranspiration, and drainage) must be completed. In this way, if two storm events are close, i.e. the inter-event time is less than the MIT, the LID performance is not completely recovered and the two events are considered to be a single storm. Therefore, the second storm that is aggregated to the previous one has wet initial soil moisture conditions

that are given by the first event. Based on the analysis of the flow hydrograph output of the SWAT model in the baseline scenario, the depletion time of the watershed without LIDs is about 2 h and was set as the lower MIT value. Then, MIT values of 3, 6, and 12 h are selected to discretize the long-term rainfall series (Behera et al., 2010). The extraction of flow events from the runoff series of the baseline and the 12 LID scenarios is done by transposing the start date time of each rainstorm event by the response time of the watershed (Figure 5). Therefore, a comparison of runoff between a given LID scenario and the others (baseline and LIDs) can be done by referring to the same chronological flow event. Likewise, the key characteristics of each rainfall event (rainstorm total volume, duration, and mean intensity) that generate a flow event, can be calculated, and associated to the same flow event (Figure 6). For every rainfall event, the key characteristics of the rainfall pattern are calculated and then associated with the percentage of PFR between every LID scenario and the baseline scenario without LIDs.

2.4 | PFR of single storm event and annual maxima

The Peak Flow Reduction - PFR is analyzed with two different approaches. First, an approach based on classes of rainstorm intensity events is proposed to analyze the performance of the LID scenario with all the storm events in the timeseries. Second, an analysis of the more extreme events is conducted to see the performance of the LID scenarios for different return periods.

In the first approach, rainstorm intensities are grouped into different classes. Every intensity class has a width of 3 mm/h. For each class (0–3 mm/h; 3–6 mm/h; 6–9 mm/h; ...) a mean PFR is evaluated with all the events following in a given class. Therefore, a mean PFR percentage of each LID scenario is associated to each class of rainfall intensity with a fitting curve, which describes the relation between mean PFR and rainfall intensity. Moreover, the mean total volume and the PFR percentage are also normalized for the unit of impervious treated area, that is the percentage of PFR is divided for the area covered by LIDs in each scenario, to assess the performance of unit area of LIDs in treating urban runoff.

In the second approach, the percentage of PFR associated with the annual maximum flow is evaluated for each LID scenario and every year of flow time series. Therefore, for every LID scenario, the return period of the annual maximum peak flow can be associated with the corresponding PFR percentage. This approach represents another interesting potentiality provided by the stochastic disaggregation methodology that allows designers to perform long-term hydrological simulations at fine temporal resolution using daily data as input and estimating the return periods from a long time series.

3 | RESULTS

Figure 6 shows the comparison between the exceedance probability (EP) of the generated (gen) and observed (obs) rainfall with respect to the volume, duration and intensity of the storm events. The figure shows how the rainfall generator slightly overestimates the intensity and the volume of the less extreme events, with a storm volume generally less than 10 mm. The difference in the EP of the rainfall intensity can

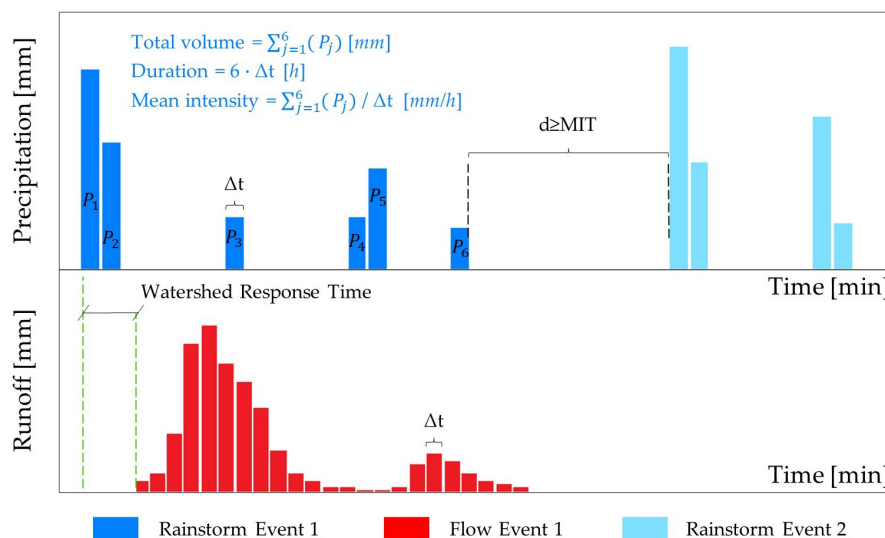

FIGURE 5 Identification of independent rainstorms and flow events in a continuous rainfall and runoff series respectively. The calculation of key characteristics of rainfall, based on single rain impulse j , associated with flow event 1 is shown in blue text/fonts.

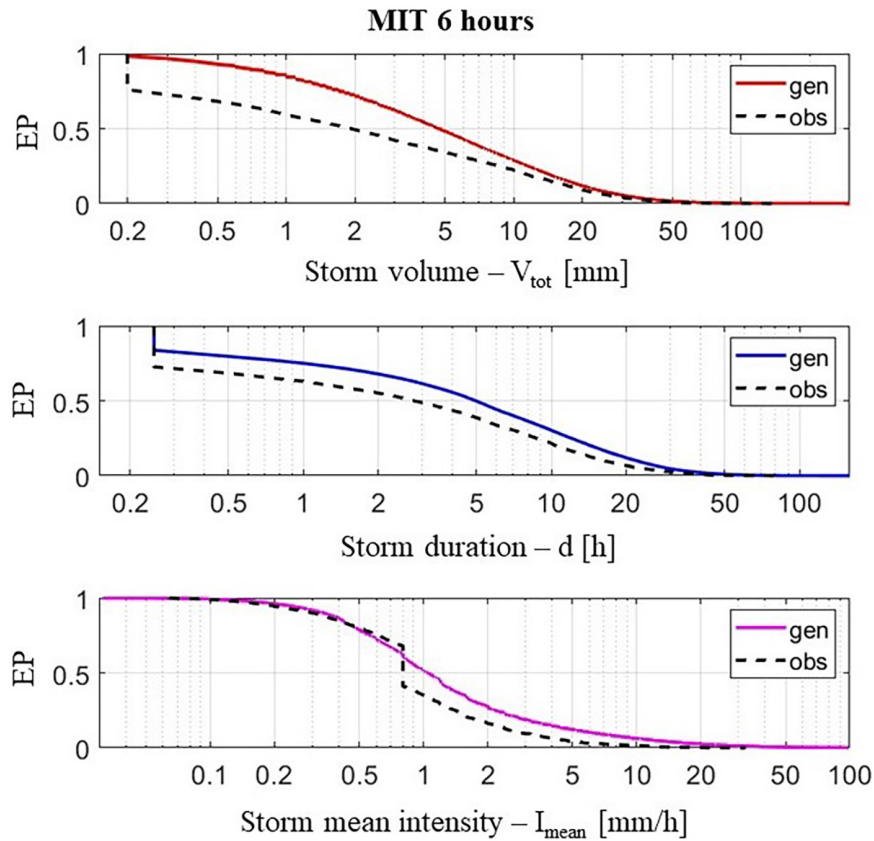

FIGURE 6 Comparison of the key characteristics of the generated and observed rainfall pattern calculated using a MIT of 6 h: (a) storm volume (mm); (b) duration of the storm event (h); (c) storm mean intensity (mm/h). EP, exceedance probability.

be attributed to the resolution of the rain gauge in the observed time series. Indeed, the precision is 0.2 mm and the time resolution is 15 min. Thus, there are a lot of rainfall events with 0.8 mm/h rainfall intensity that have been measured, while the generator reproduces the intensity in a continuous way. Nevertheless, Rainsim is able to reproduce the EP of the rainfall intensity properly. The graphs in Figure 7 show the results of the PFR of each LID scenario with respect to the rainfall intensity. Figure 7a,b show the runoff reduction capability of a single combination of GRs and RGs, respectively. GRs runoff reduction (Figure 7a) depends mainly on the intensity of the rainstorm event, showing a similar behavior across the entire range of impervious treated areas scenarios. On the contrary, Figure 7b shows that the relation between PFR and rainfall intensity in RGs has a different behavior as the percentage of impervious treated area increases.

For smaller to medium percentages of impervious treated area (25%–50%), isolated RGs are demanded to treat water that drops directly from surrounding impervious areas. Ponding is counteracted by soil drainage capacity and PFR efficiency increases until a higher rainstorm intensity event occurs. Then, the amended soil layers reach its field capacity and ponding becomes predominant, thus, PFR capability is reduced. This behavior is more pronounced as the intensity of the rainstorm event increases (Figure 7b).

Otherwise, when percentages of impervious treated areas are higher than 50%, synergy between every RGs and PFR increases with rainstorm intensities.

Combinations of different LID types increase the reduction of flow peak percentage, and it increases further when LIDs area increases (Figure 7c).

It has to be noted that the results have been reported always considering a fixed MIT, however a sensitivity analysis was carried out to evaluate the effects of MIT variation on PFR. As shown in Figure 8, the effects of all MITs (3, 6 and 12 h) on PFR are negligible when the percentages of impervious area treated, and LID type are fixed.

Considering the maximum percentage of PFR of the different LID types (Table 4), GRs have the lowest performance (ranging between 15% to 44% of PFR for the GR-25 and GR-100 scenarios respectively). On the contrary, the performance of RGs configurations almost doubled for smaller percentages of impervious treated area and remains higher than that of GRs as the treated area increases (up to 55%).

As also reported in Table 4, the maximum PFR increases when the GRs and RGs are combined in an integrated configuration.

In order to better characterize the specific performances of GRs and RGs and allow their comparison, their effects have been analyzed considering the associated PFR capability per unit of impervious area treated, dividing the PFR percentages by the area where the LIDs are installed (Figure 9).

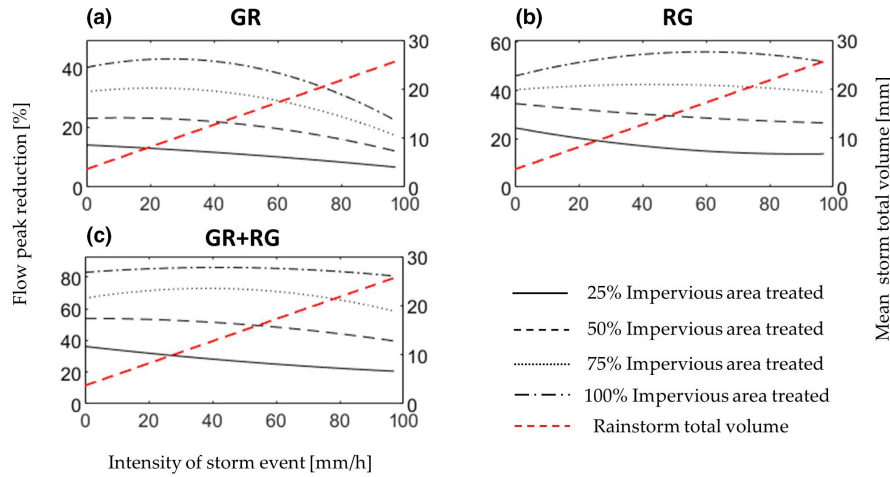

FIGURE 7 Percentages of flow peak reduction associated with classes of rainstorm event intensities calculated with a MIT of 6 h. The effects of increasing percentages of impervious treated area inside every HRU are shown for the three LID combinations analyzed: GR (a), RG (b) as well as for their combination GR+RG (c). The mean rainstorm total volume trend for each intensity storm event class is also shown.

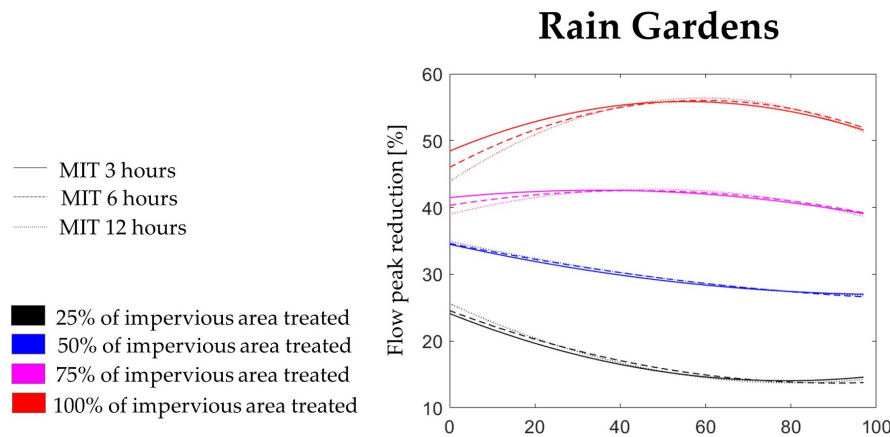

FIGURE 8 MIT sensitivity analysis on RG's percentages of peak flow reduction associated with classes of rainstorm event intensities.

TABLE 4 Maximum flow peak reduction percentages associated with rainstorm intensities for each LID scenario combining different LID types (GR and RG) and percentage of treated area (25%, 50%, 75%, and 100%), using a MIT of 6 h. Values refer to the mean peak flow reduction (PFR) of flow events belonging to each rainstorm intensity class.

LID scenario	Max PFR (%)	Associated rainstorm intensity (mm/h)
GR-25	15.3	1.5
GR-50	23.6	19.5
GR-75	34.2	16.5
GR-100	44.2	22.5
RG-25	30.8	1.5
RG-50	37.9	1.5
RG-75	43.3	28.5
RG-100	55.9	37.5
GR+RG-25	40.8	1.5
GR+RG-50	55.6	1.5
GR+RG-75	74.4	37.5
GR+RG-100	87.9	44.5

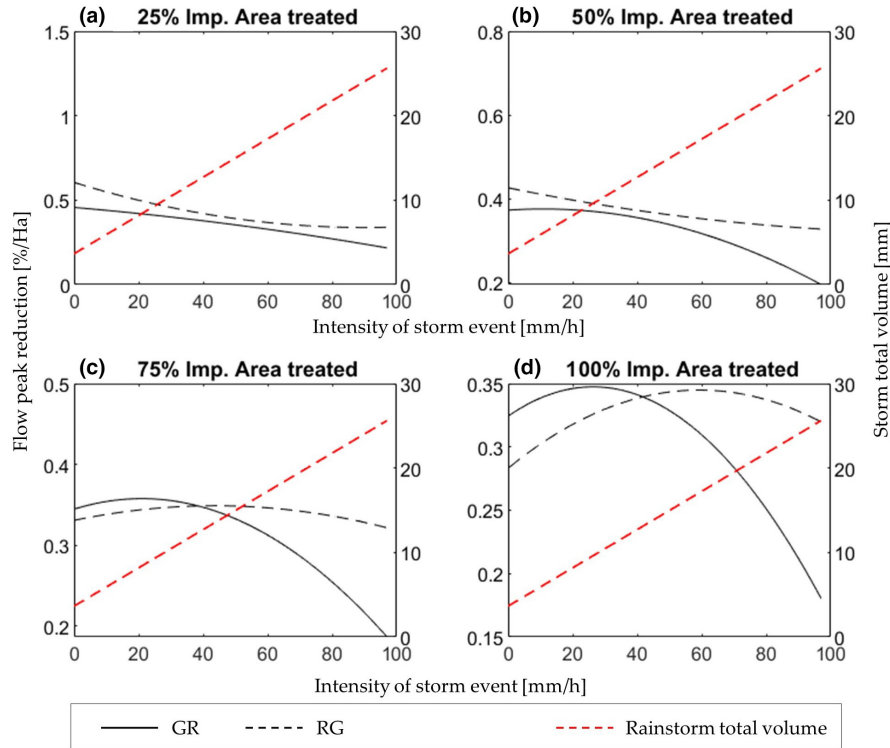

FIGURE 9 Percentages of flow peak reduction for unit of impervious treated area, associated with classes of rainstorm event intensities that are calculated with a MIT of 6 h. Effects of increasing percentages of impervious treated area within a HRU are shown for the studied LID types; (a) for 25%; (b) for 50%; (c) for 75% and (d) for 100%. The mean rainstorm total volume trend with respect to the intensity of each storm event is also shown.

Results show that, for a given rainstorm intensity, the PFR per unit of area is decreasing while the share of impervious areas treated increases. This is due to the non linear relationships occurring between PFR and the extension of the area where LIDs are installed. For instance, considering a rainstorm event of 20 mm/h, GRs show a PFR of around 0.45% per hectare in the scenario with 25% of impervious area treated. The PFR decreases to 0.34% per hectare when the impervious area treated is 100%. This reflects the behavior already shown in Figure 7a where a variation of treated areas from 25% to 100% corresponds to an absolute PFR increase from 15% to 42%.

Moreover, results show that RGs perform better than GRs for intensities of rainstorms greater than 40 mm/h, while the GRs have better performances with lower rainstorm events and percentages of treated areas above 50%. However, the gap between the two LID types decreases continuously as the percentage of treated area increases.

Finally, the PFR capabilities provided by the different LID implementation scenarios have been analyzed with an approach based on return periods of annual maximum peak flow (Figure 10).

The results show that in GRs the PFR capability decreases as the return periods of runoff increase, i.e., with higher annual maximum peak flows. In contrast, the single RG configuration (Figure 10b) provides a more stable peak flow treatment as the return period increases. Similarly, the combination of GR and RG exhibits a PFR plateau for annual maximum peak flows with return periods older than 50 years. Table 5 presents the mean annual PFR for 500 years and for every LID scenario. It can be argued that the best PFR capacity, with regard to annual maximum peak flows, is provided by the GR + RG with a mean annual PFR ranging between 22% and 80%.

4 | DISCUSSION

The proposed analysis allows the quantitative evaluation of GRs and RGs performances in reducing the peak flows, supporting the correct implementation of the different LIDs types in a given area, as discussed in the following paragraphs.

The GR behavior can be explained since every GR unit is built independently to others, and its effect is driven by the infiltration and evapotranspiration processes caused by the amended soil layers, thus they do not interact with hydrological processes of other GRs. In agreement with Guan et al. (2015), GR practices performed better in a monthly rainstorm scenario than in a single hourly event, and PFR generally

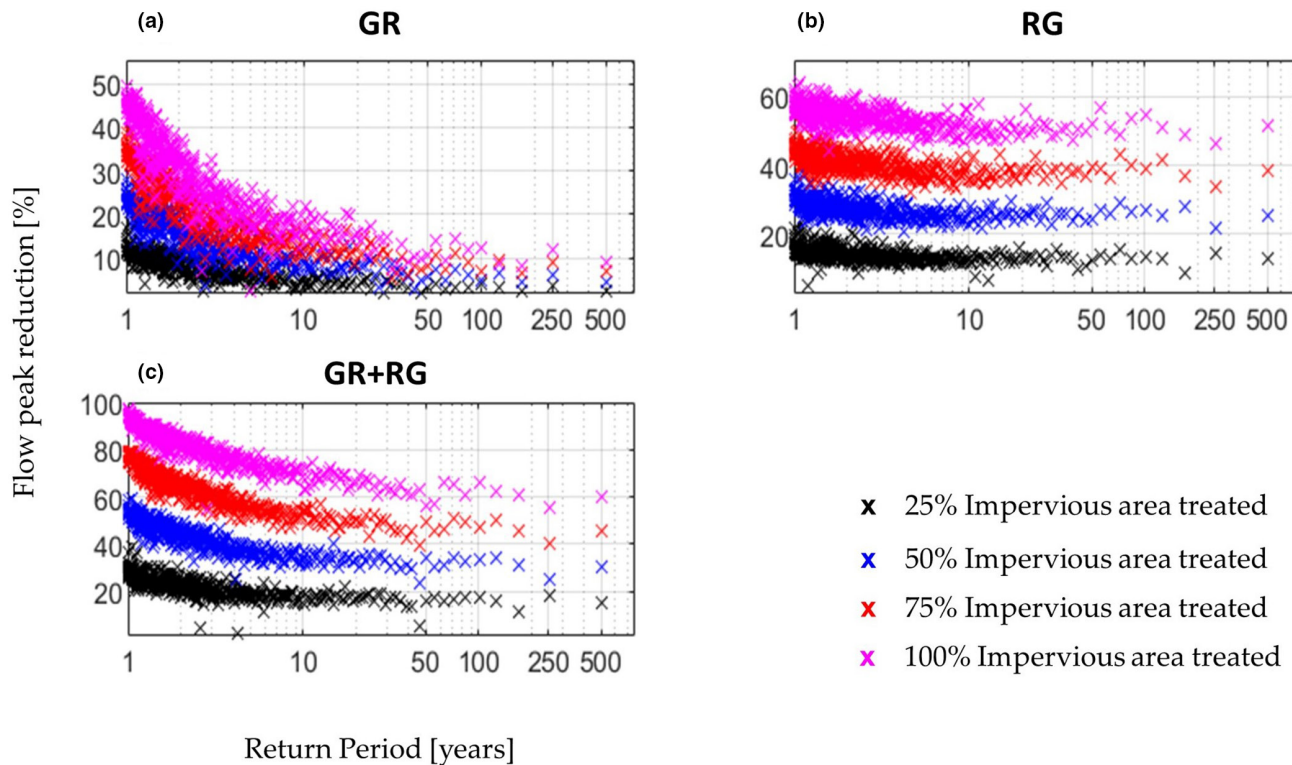

FIGURE 10 Percentage of flow peak reduction associated with the maximum annual runoff with different return periods. Effects of increasing percentages of impervious treated area inside every HRU are shown for RG (a), RG (b) and their combination GR+RG (c).

TABLE 5 Mean of annual flow peak reduction percentages over the 500-years period analyzed.

LID scenario	Mean annual PFR (%)
GR–25	8.4
GR–50	15.7
GR–75	22.7
GR–100	29.7
RG–25	14
RG–50	27.4
RG–75	40.7
RG–100	54
GR + RG–25	22
GR + RG–50	43
GR + RG–75	63.4
GR + RG–100	80

decreased during rainfall events of high magnitude. The results obtained for the maximum percentage of PFR agree with Cipolla et al. (2016) that determine a GRs annual average runoff removal rate of 51.9%, whereas it drops from 6.4% to 50% for single rainfall events.

Concerning the RGs, their water storage and treatment capacity is influenced by: (i) high infiltration rate due to the properties of the amended soil layer, (ii) surface ponding, (iii) orifice pipe installed in the surface storage. Once the stage of ponding water is higher than that of an orifice installed in the surface storage, the ponding water starts to drain toward the orifice. The results of Figure 7 shows how the RG behavior is strictly dependent on the share of impermeable treated area with ponding becoming predominant when RGs cover more than 50% of the impervious area. Also in this case, the results obtained for the maximum percentage of PFR are in line with those identified in literature (e.g. average PFR of 71% estimated by Schlea et al. (2014)).

It has to be noted that the results may be affected by the scarcity of data for calibration. However, since the study focuses on the analysis of runoff differences between different LID scenarios located across the study watershed, the limitations on calibration can be overcome by

only focusing on the relative changes induced by modification of land use in the main urban hydrological processes (Niraula et al., 2015; Pacetti et al., 2020; Zubeľzu et al., 2020). Another aspect to take into account is the use of a stationary stochastic rainfall generator model (as Rainsim V.3 used in this case) to simulate sub-daily rainfall records from observed data. Indeed climate change effects or possible long-term variations of the rainfall were not considered, and they would be included in further studies. In addition, an approach based on multiple non-stationary stochastic rainfall generator may be an interesting future choice since global climate change may affect the urban microclimate and have implications for designing stormwater and flood control measures for watershed management (Ghodsı et al., 2020; Pour et al., 2020). Therefore, these considerations may limit the generalization of the results and conclusions.

Despite these limitations, the proposed methodology may provide a useful tool for the design of LIDs providing quantitative understanding of their hydrological behavior. Moreover, the results obtained can be combined with a more detailed analysis on LID spatial planning constraints, as already developed for the area of study by Pacetti et al. (2022), providing an integrated assessment of LID feasibility and effectiveness.

5 | CONCLUSIONS

In this paper, a long-term analysis of LID effects was carried out at the urban watershed scale by coupling the stochastic spatial-temporal generator RainSim V.3. and the SWAT model. The study provides a methodology to (i) implement several LID scenarios by using the SWAT-LID module, changing the type of infrastructure and varying the percentage of retrofitted impervious area; (ii) analyze the maximum PFR of every LID scenario both for single storm events and for an annual maxima over a 500-year hydrological simulation.

Despite the obtained results and conclusions being restricted to the selected rain gauge and urban watershed area, the study highlights that the stochastic methodology adopted can contribute to the analysis of several LID scenarios hydrological behavior at a watershed scale over discontinuous wet and dry periods, allowing the use of sub-daily MITs to separate independent rainstorm and flow events. The results obtained suggest the importance of carrying out a detailed hydrological characterization of LIDs to improve the correct understanding of their behavior at the urban watershed hydrology scale, supporting their planning and their implementation.

AUTHOR CONTRIBUTIONS

Matteo Pampaloni: Conceptualization; data curation; formal analysis; investigation; methodology; software; writing – original draft. **Alvaro Sordo-Ward:** Conceptualization; formal analysis; methodology; resources; supervision; writing – review and editing. **Marco Lompi:** Data curation; formal analysis; writing – review and editing. **Tommaso Pacetti:** Data curation; formal analysis; supervision; writing – review and editing. **Sergio Zubeľzu:** Formal analysis; writing – review and editing. **Leonor Rodrıguez-Sinobas:** Formal analysis; writing – review and editing. **Paola Bianucci:** Conceptualization; writing – review and editing. **Enrica Caporali:** Supervision; writing – review and editing. **Luis Garrote:** Conceptualization; supervision; writing – review and editing.

ACKNOWLEDGMENTS

The authors wish to thank the Hydrological Service of Tuscany Region for the availability of the dataset. Specific acknowledgments are for Prof. Jaehak Jeong and Young Gu Her for their valuable support in the preliminary phases of the research.

CONFLICT OF INTEREST STATEMENT

The authors declare that they have no conflicts of interest.

DATA AVAILABILITY STATEMENT

The data that support the findings of this study are available from the corresponding author upon reasonable request.

ORCID

A. Sordo-Ward  <https://orcid.org/0000-0002-9186-8395>
M. Lompi  <https://orcid.org/0000-0003-2970-168X>
T. Pacetti  <https://orcid.org/0000-0002-8533-0804>
S. Zubeľzu  <https://orcid.org/0000-0003-3637-5085>
L. Rodrıguez-Sinobas  <https://orcid.org/0000-0001-9684-6884>
P. Bianucci  <https://orcid.org/0000-0001-7297-1082>
E. Caporali  <https://orcid.org/0000-0001-6389-3801>
L. Garrote  <https://orcid.org/0000-0001-9087-3638>

REFERENCES

- Ahiablame, Laurent M., Bernard A. Engel, and Indrajeet Chaubey. 2013. "Effectiveness of Low Impact Development Practices in Two Urbanized Watersheds: Retrofitting with Rain Barrel/Cistern and Porous Pavement." *Journal of Environmental Management* 119: 151–61. <https://doi.org/10.1016/j.jenvman.2013.01.019>.
- Andrés-Doménech, I., A. Montanari, and J.B. Marco. 2010. "Stochastic Rainfall Analysis for Storm Tank Performance Evaluation." *Hydrology and Earth System Sciences* 14(7): 1221–32. <https://doi.org/10.5194/hess-14-1221-2010>.
- Andrés-Doménech, Ignacio, Sara Perales-Momparler, Adrián Morales-Torres, and Ignacio Escuder-Bueno. 2018. "Hydrological Performance of Green Roofs at Building and City Scales under Mediterranean Conditions." *Sustainability* 10(9): 3105. <https://doi.org/10.3390/su10093105>.
- Bai, Yiran, Yuhong Li, Ruoyu Zhang, Na Zhao, and Xiaofan Zeng. 2019. "Comprehensive Performance Evaluation System Based on Environmental and Economic Benefits for Optimal Allocation of LID Facilities." *Water* 11(2): 341. <https://doi.org/10.3390/w11020341>.
- Behera, Pradeep K., Yiping Guo, Ramesh S. Teegavarapu, and Travis Branham. 2010. "Evaluation of Antecedent Storm Event Characteristics for Different Climatic Regions Based on Interevent Time Definition (IETD)." [https://doi.org/10.1061/41114\(371\)251](https://doi.org/10.1061/41114(371)251).
- Brighenti, T.M., N.B. Bonumá, R. Srinivasan, and P.L.B. Chaffe. 2019. "Simulating Sub-Daily Hydrological Process with SWAT: A Review." *Hydrological Sciences Journal* 64(12): 1415–23.
- Burton, A., H.J. Fowler, C.G. Kilsby, and P.E. O'Connell. 2010. "A Stochastic Model for the Spatial-Temporal Simulation of Nonhomogeneous Rainfall Occurrence and Amounts." *Water Resources Research* 46(11): W11501. <https://doi.org/10.1029/2009WR008884>.
- Burton, A., C.G. Kilsby, H.J. Fowler, P.S.P. Cowpertwait, and P.E. O'Connell. 2008. "RainSim: A Spatial-Temporal Stochastic Rainfall Modelling System." *Environmental Modelling and Software* 23(12): 1356–69. <https://doi.org/10.1016/j.envsoft.2008.04.003>.
- Caporali, Enrica, Marco Lompi, Tommaso Pacetti, Valentina Chiarello, and Simone Fatichi. 2021. "A Review of Studies on Observed Precipitation Trends in Italy." *International Journal of Climatology* 41: 1–25. <https://doi.org/10.1002/joc.6741>.
- Cipolla, Sara Simona, Marco Maglionico, and Irena Stojkov. 2016. "A Long-Term Hydrological Modelling of an Extensive Green Roof by Means of SWMM." *Ecological Engineering* 95: 876–87. <https://doi.org/10.1016/j.ecoleng.2016.07.009>.
- de Sousa, Catalano, Maria Raquel, Franco Andre Montalto, and Patrick Gurian. 2016. "Evaluating Green Infrastructure Stormwater Capture Performance under Extreme Precipitation." *Journal of Extreme Events* 3(2): 1650006. <https://doi.org/10.1142/s2345737616500068>.
- Ercolani, Giulia, Enrico Antonio Chiaradia, Claudio Gandolfi, Fabio Castelli, and Daniele Masseroni. 2018. "Evaluating Performances of Green Roofs for Stormwater Runoff Mitigation in a High Flood Risk Urban Catchment." *Journal of Hydrology* 566: 830–45. <https://doi.org/10.1016/j.jhydrol.2018.09.050>.
- Fatichi, Simone, and Enrica Caporali. 2009. "A Comprehensive Analysis of Changes in Precipitation Regime in Tuscany." *International Journal of Climatology* 29: 1883–93. <https://doi.org/10.1002/joc.1921>.
- Ghods, Seyed Hamed, Zahra Zahmatkesh, Erfan Goharian, Reza Kerachian, and Zhenduo Zhu. 2020. "Optimal Design of low Impact Development Practices in Response to Climate Change." *Journal of Hydrology* 580: 124266. <https://doi.org/10.1016/j.jhydrol.2019.124266>.
- Gong, Yongwei, Xianwei Zhang, Haiyan Li, Xiaoran Zhang, Song He, and Yuhong Miao. 2021. "A Comparison of the Growth Status, Rainfall Retention and Purification Effects of Four Green Roof Plant Species." *Journal of Environmental Management* 278: 111451. <https://doi.org/10.1016/j.jenvman.2020.111451>.
- Guan, Mingfu, Nora Sillanpää, and Harri Koivusalo. 2015. "Assessment of LID Practices for Restoring Pre-Development Runoff Regime in an Urbanized Catchment in Southern Finland." *Water Science and Technology* 71(10): 1485–91. <https://doi.org/10.2166/wst.2015.129>.
- Her, Younggu, Jaehak Jeong, Jeffrey Arnold, Leila Gosselink, Roger Glick, and Fouad Jaber. 2017. "A New Framework for Modeling Decentralized Low Impact Developments Using Soil and Water Assessment Tool." *Environmental Modelling and Software* 96: 305–22. <https://doi.org/10.1016/j.envsoft.2017.06.005>.
- Hoghooghi, Nahal, Heather E. Golden, Brian P. Bledsoe, Bradley L. Barnhart, Allen F. Brookes, Kevin S. Djang, Jonathan J. Halama, Robert B. McKane, Christopher T. Nietch, and Paul P. Pettus. 2018. "Cumulative Effects of Low Impact Development on Watershed Hydrology in a Mixed Land-Cover System." *Water* 10(8): 991. <https://doi.org/10.3390/w10080991>.
- Huang, Yijing, Zhan Tian, Qian Ke, Junguo Liu, Masoud Irannezhad, Dongli Fan, Meifang Hou, and Laixiang Sun. 2020. "Nature-Based Solutions for Urban Pluvial Flood Risk Management." *WIREs Water* 7(3): 1–17. <https://doi.org/10.1002/wat2.1421>.
- Jeong, Jaehak, Narayanan Kannan, Jeff Arnold, Roger Glick, Leila Gosselink, and Raghavan Srinivasan. 2010. "Development and Integration of Sub-Hourly Rainfall-Runoff Modeling Capability within a Watershed Model." *Water Resources Management* 24(15): 4505–27. <https://doi.org/10.1007/s11269-010-9670-4>.
- Kaykhosravi, Sahereh, Usman T. Khan, and Amaneh Jadidi. 2018. "A Comprehensive Review of Low Impact Development Models for Research, Conceptual, Preliminary and Detailed Design Applications." *Water* 10(11): 1541. <https://doi.org/10.3390/w10111541>.
- Kim, Heenyun, and Gunwoo Kim. 2021. "An Effectiveness Study on the Use of Different Types of lid for Water Cycle Recovery in a Small Catchment." *Land* 10(10): 1055. <https://doi.org/10.3390/land10101055>.
- Lefebvre, Antoine, Christophe Sannier, and Thomas Corpetti. 2016. "Monitoring Urban Areas with Sentinel-2A Data: Application to the Update of the Copernicus High Resolution Layer Imperviousness Degree." *Remote Sensing* 8(7): 606. <https://doi.org/10.3390/rs8070606>.
- Li, Jiake, Chenning Deng, Ya Li, Yajiao Li, and Jinxi Song. 2017. "Comprehensive Benefit Evaluation System for Low-Impact Development of Urban Stormwater Management Measures." *Water Resources Management* 31(15): 4745–58. <https://doi.org/10.1007/s11269-017-1776-5>.
- Li, Jiake, Ruisong Zhao, Yajiao Li, and Li Chen. 2018. "Modeling the Effects of Parameter Optimization on Three Bioretention Tanks Using the HYDRUS-1D Model." *Journal of Environmental Management* 217: 38–46. <https://doi.org/10.1016/j.jenvman.2018.03.078>.
- Maharjan, Ganga Ram, Youn Shik Park, Nam Won Kim, Dong Seok Shin, Jae Wan Choi, Geun Woo Hyun, Ji Hong Jeon, Yong Sik Ok, and Kyoung Jae Lim. 2013. "Evaluation of SWAT Sub-Daily Runoff Estimation at Small Agricultural Watershed in Korea." *Frontiers of Environmental Science and Engineering in China* 7(1): 109–19. <https://doi.org/10.1007/s11783-012-0418-7>.
- Marhaento, Hero, Martijn J. Booij, T.H.M. Rientjes, and Arjen Y. Hoekstra. 2019. "Sensitivity of Streamflow Characteristics to Different Spatial Land-Use Configurations in Tropical Catchment." *Journal of Water Resources Planning and Management* 145(12): 04019054. [https://doi.org/10.1061/\(asce\)wr.1943-5452.0001122](https://doi.org/10.1061/(asce)wr.1943-5452.0001122).

- Massoudieh, Arash, Mahdi Maghrebi, Babak Kamrani, Christopher Nietch, Michael Tryby, Sassan Aflaki, and Srinivas Panguluri. 2017. "A Flexible Modeling Framework for Hydraulic and Water Quality Performance Assessment of Stormwater Green Infrastructure." *Environmental Modelling and Software* 92: 57–73. <https://doi.org/10.1016/j.envsoft.2017.02.013>.
- Mein, R.G., and C.L. Larson. 1973. "Modeling Infiltration during a Steady Rain." *Water Resources Research* 9(2): 384–94.
- Morbideilli, R., A.P. García-Marín, A. Al Mamun, R.M. Atiqur, J.L. Ayuso-Muñoz, M.B. Taouti, P. Baranowski, et al. 2020. "The History of Rainfall Data Time-Resolution in a Wide Variety of Geographical Areas." *Journal of Hydrology* 590: 125258. <https://doi.org/10.1016/j.jhydrol.2020.125258>.
- Neitsch, S.L., J.G. Arnold, J.R. Kiniry, J.R. Williams, and K.W. King. 2005. *SWAT Theoretical Documentation Version 2005*. Temple, TX: Soil and Water Research Laboratory, ARS.
- Niraula, Rewati, Thomas Meixner, and Laura M. Norman. 2015. "Determining the Importance of Model Calibration for Forecasting Absolute/Relative Changes in Streamflow from LULC and Climate Changes." *Journal of Hydrology* 522: 439–51. <https://doi.org/10.1016/j.jhydrol.2015.01.007>.
- Pacetti, T., S. Cioli, G. Castelli, E. Bresci, M. Pampaloni, T. Pileggi, and E. Caporali. 2022. "Planning Nature Based Solutions against Urban Pluvial Flooding in Heritage Cities: A Spatial Multi Criteria Approach for the City of Florence (Italy)." *Journal of Hydrology: Regional Studies* 41: 101081.
- Pacetti, Tommaso, Marco Lompi, Claudio Petri, and Enrica Caporali. 2020. "Mining Activity Impacts on Soil Erodibility and Reservoirs Silting: Evaluation of Mining Decommissioning Strategies." *Journal of Hydrology* 589: 125107. <https://doi.org/10.1016/j.jhydrol.2020.125107>.
- Pampaloni, Matteo, Alvaro Sordo-Ward, Paola Bianucci, Ivan Gabriel-Martin, Enrica Caporali, and Luis Garrote. 2021. "A Stochastic Procedure for Temporal Disaggregation of Daily Rainfall Data in SuDS Design." *Water* 13(4): 403. <https://doi.org/10.3390/w13040403>.
- Pour, Sahar Hadi, Ahmad Khairi Abd Wahab, Shamsuddin Shahid, Md Asaduzzaman, Ashraf Dewan. 2020. Low Impact Development Techniques to Mitigate the Impacts of Climate-Change-Induced Urban Floods: Current Trends, Issues and Challenges. *Sustainable Cities and Society* 62: 102373. <https://doi.org/10.1016/j.scs.2020.102373>
- Rezaei, Abdul Razaq, Zubaidah Ismail, Mohammad Hossein Niksokhan, Muhammad Amin Dayarian, Abu Hanipah Ramli, and Sharif Moniruzzaman Shirazi. 2019. "A Quantity-Quality Model to Assess the Effects of Source Control Stormwater Management on Hydrology and Water Quality at the Catchment Scale." *Water* 11(7): 1415. <https://doi.org/10.3390/w11071415>.
- Roy-Poirier, Audrey, Pascale Champagne, and Yves Filion. 2010. "Review of Bioretention System Research and Design: Past, Present, and Future." [https://doi.org/10.1061/\(ASCE\)EE.1943-7870.0000227](https://doi.org/10.1061/(ASCE)EE.1943-7870.0000227).
- Schlea, D., J.F. Martin, A.D. Ward, L.C. Brown, and S.A. Suter. 2014. "Performance and Water Table Responses of Retrofit Rain Gardens." *Journal of Hydrologic Engineering* 19(8): 05014002.
- Seo, Mijin, Fouad Jaber, Raghavan Srinivasan, and Jaehak Jeong. 2017. "Evaluating the Impact of Low Impact Development (LID) Practices on Water Quantity and Quality under Different Development Designs Using SWAT." *Water* 9(3): 193. <https://doi.org/10.3390/w9030193>.
- Shannak, Sa'd. 2017. "The Effects of Green Infrastructure on Exceedance of Critical Shear Stress in Blunn Creek Watershed." *Applied Water Science* 7(6): 2975–86. <https://doi.org/10.1007/s13201-017-0606-5>.
- Sordo-Ward, Alvaro, Ivan Gabriel-Martin, and Luis Garrote. 2019. "Characterisation of the Sensitivity of Water Resources Systems to Climate Change View Project Water Resources Management View Project." *Revista de Obras Públicas* 3607(3607): 28–31.
- Stovin, Virginia, Simon Poë, and Christian Berretta. 2013. "A Modelling Study of Long Term Green Roof Retention Performance." *Journal of Environmental Management* 131: 206–15. <https://doi.org/10.1016/j.jenvman.2013.09.026>.
- Turco, Michele, Radka Kodešová, Giuseppe Brunetti, Antonin Nikodem, Miroslav Fér, and Patrizia Piro. 2017. "Unsaturated Hydraulic Behaviour of a Permeable Pavement: Laboratory Investigation and Numerical Analysis by Using the HYDRUS-2D Model." *Journal of Hydrology* 554: 780–91. <https://doi.org/10.1016/j.jhydrol.2017.10.005>.
- Uniyal, Bhumika, Madan K. Jha, Arvind Kumar Verma, and Prajna Kasargodu Anebagilu. 2020. "Identification of Critical Areas and Evaluation of Best Management Practices Using SWAT for Sustainable Watershed Management." *Science of the Total Environment* 744: 140737. <https://doi.org/10.1016/j.scitotenv.2020.140737>.
- Wadzuk, Bridget M., Conor Lewellyn, Ryan Lee, and Robert G. Traver. 2017. "Green Infrastructure Recovery: Analysis of the Influence of Back-to-Back Rainfall Events." *Journal of Sustainable Water in the Built Environment* 3(1): 04017001. <https://doi.org/10.1061/jswbay.0000819>.
- Woods Ballard, B., and Construction Industry Research and Information Association. 2015. *The SuDS Manual*. London: CIRIA.
- Yang, Wenyu, Kurt Brüggemann, Kiwanuka David Seguya, Ehtesham Ahmed, Thomas Kaeseberg, Heng Dai, Pei Hua, Jin Zhang, and Peter Krebs. 2020. "Measuring Performance of Low Impact Development Practices for the Surface Runoff Management." *Environmental Science and Ecotechnology* 1: 100010. <https://doi.org/10.1016/j.ese.2020.100010>.
- Zhang, Shouhong, and Yiping Guo. 2013. "Explicit Equation for Estimating Storm-Water Capture Efficiency of Rain Gardens." *Journal of Hydrologic Engineering* 18(12): 1739–48. [https://doi.org/10.1061/\(asce\)he.1943-5584.0000734](https://doi.org/10.1061/(asce)he.1943-5584.0000734).
- Zubelzu, S., L. Rodríguez-Sinobas, I. Andrés-Domenech, J.T. Castillo-Rodríguez, and S. Perales-Momparler. 2019. "Design of Water Reuse Storage Facilities in Sustainable Urban Drainage Systems from a Volumetric Water Balance Perspective." *Science of the Total Environment* 663: 133–43. <https://doi.org/10.1016/j.scitotenv.2019.01.342>.
- Zubelzu, Sergio, Leonor Rodríguez-Sinobas, Alvaro Sordo-Ward, Alan Pérez-Durán, and Rodolfo Cisneros-Almazán. 2020. "Multi-Objective Approach for Determining Optimal Sustainable Urban Drainage Systems Combination at City Scale. The Case of San Luis Potosi (Mexico)." *Water* 12(3): 1–17. <https://doi.org/10.3390/w12030835>.

How to cite this article: Pampaloni, M., A. Sordo-Ward, M. Lompi, T. Pacetti, S. Zubelzu, L. Rodríguez-Sinobas, P. Bianucci, E. Caporali and L. Garrote 2024. "Performance of Low Impact Development on Peak Flow Reduction in an Urban System." *JAWRA Journal of the American Water Resources Association* 60 (2): 427–441. <https://doi.org/10.1111/1752-1688.13188>.